

TYPHOON®

**PLASTIC  
PRESSURE  
REDUCING**

HYDRAULIC CONTROL VALVE





# We Care Every Drop of Water...

That is why our company, which has been developing products in the field of water systems for over 20 years, offers increasingly efficient solutions every day. With our expertise and experience, we continue to develop innovative technologies for the proper control and sustainable use of water.

## OUR PRODUCTION CAPACITY IS INCREASING! OUR GOALS ARE BIGGER!

We have been wherever there is water since 2004.

Founded in Izmir by Tayfun Yazarođlu, TAYFUR WATER SYSTEMS set out with the belief that water is the source of life. Beginning with the production of hydraulic control valves, this journey has now transformed into a strong and reliable brand offering innovative solutions across a wide range of areas, including irrigation, drinking water, firefighting and industrial systems.

In every project, while determining the direction of water, we are also shaping the sustainable infrastructure of the future. From production to project design, from installation to technical support, we work without compromising on high quality standards, with our state-of-the-art facilities and expert team. We aim to offer our customers not just products, but also trust, continuity and technical excellence.

TYPHOON branded products are developed entirely with our own production capabilities and local engineering expertise. These products stand out not only for their durability, but also for our philosophy of preserving the value of every drop. Thanks to our production processes that comply with international standards and our customer satisfaction-focused approach, we are proud to be recognised as a reliable business partner both domestically and globally.

Today, TAYFUR WATER SYSTEMS, a brand with roots in Izmir, continues on its path with the vision of being a symbol of quality, innovation, and trust wherever water is present.





## *Agricultural Irrigation Systems*

The foundation of efficient agricultural production lies in delivering water at the right time, in the right quantity, and to the right location. Modern agricultural irrigation systems ensure both the efficient use of water resources and an increase in product quality and yield. The solutions developed in this context enable farmers to achieve a sustainable production structure independent of climatic conditions.

At TAYFUR WATER SYSTEMS, with our many years of engineering experience in the field of agricultural irrigation, we manufacture critical components such as hydraulic control valves, suction valves, backwash valves and meters to high quality standards. Each of our products saves energy by increasing the automation capabilities of the systems, prevents water wastage and minimises maintenance requirements. Thus, we offer reliable and long-lasting solutions for both small-scale businesses and large agricultural projects.

The products we develop are designed in accordance with international standards and tested to deliver maximum performance in challenging field conditions. At TAYFUR WATER SYSTEMS, our goal is to provide smart, durable, and sustainable systems for producers who value every drop. Because we believe that by determining the direction of water, we are shaping the future of agriculture.



## *Industrial Area Systems*

Proper water management in industrial facilities is critical to the efficiency and sustainability of production processes. Every application, from pressurised lines to cooling circuits, fire systems to process lines, requires precise control and high durability. Therefore, the performance of equipment used in industrial systems is directly related to facility safety and operational continuity.

At TAYFUR WATER SYSTEMS, we manufacture products that play a critical role in industrial applications, such as hydraulic control valves, backwash valves, vacuum breakers, and meters, to high engineering standards. Our products adapt to harsh working conditions with their high pressure resistance, corrosion resistance, and long service life. By providing complete control over fluid management, they increase energy efficiency in systems and minimise maintenance times.

Designed to comply with international standards, our solutions are trusted across a wide range of applications, from factories to power plants, water treatment facilities to infrastructure projects. At TAYFUR WATER SYSTEMS, our goal is to make industrial water management smarter, safer and more sustainable, providing our customers with the assurance of uninterrupted operations.



## *Fire Systems*

Fire safety is one of the most vital elements of every structure, from industrial facilities to public buildings, infrastructure projects to living spaces. The reliability of the equipment used in these systems is critical not only for the protection of the facility but also for the protection of human life.

As TAYFUR WATER SYSTEMS, we are a company specialising in the production of hydraulic control valves to ensure maximum safety in fire lines. Our products are designed to guarantee the fast, reliable and uninterrupted operation of fire systems. These valves, which stand out for their high pressure resistance, leak-proof performance and long service life, are tested in accordance with international standards and offered with quality assurance.

With our advanced engineering infrastructure and production experience, we produce solutions that can be used safely in various applications, from automatic sprinkler systems to fire pump stations. At TAYFUR WATER SYSTEMS, our goal is not just to manufacture products; it is to be part of systems that make a difference in fire safety, inspire confidence, and protect life.



## *Filter Automation*

Water is a vital resource that must be managed with maximum efficiency during the filtration stage, as it is in many industrial and agricultural processes. Proper automation in filtration systems is critical in terms of energy savings, ease of maintenance, and system continuity. An effective filter automation system determines not only the quality of the water but also the lifespan and efficiency of the entire system.

At TAYFUR WATER SYSTEMS, we offer comprehensive solutions in the field of filter automation. Our products, such as hydraulic control valves, backwash valves and panels, bottom valves, and dirt traps, ensure precise flow management in automatic filter systems. Our products optimise the water filtration process while performing backwashing operations precisely and efficiently. This reduces the risk of clogging in systems, prevents energy losses, and extends maintenance intervals.

All our products stand out with their durable material construction, precise control capability, and long-lasting design. At TAYFUR WATER SYSTEMS, our goal is to provide our customers with smart, reliable, and sustainable automation solutions by maximising efficiency in filtration processes. Because we believe that water purity begins with system safety.

## Pressure Reducing Control Valve



TYPHOON Plastic Pressure Reducing Control Valves are automatic plastic hydraulic control valves that reduce the system inlet pressure to the desired outlet pressure using a built-in pressure-reducing pilot. The valve continuously monitors the set outlet pressure, regardless of fluctuations in inlet pressure and flow rate, ensuring stable system operation. The valve automatically closes when there is no flow; it automatically opens when the inlet pressure drops below the outlet pressure.

The plastic body and diaphragm design ensures smooth flow with minimal pressure loss and ensures long-lasting, durable operation. TYPHOON Plastic Pressure Reducing Control Valves can be installed in horizontal or vertical positions and provide reliable and energy-efficient pressure control in a variety of applications, including agricultural irrigation, drinking water lines, filtration, and industrial applications.

Pressure Range : PN 10  
Diameters : 3/4" - 1" - 1 1/2" - 2" - 2 1/2" - 3"R - 3" - 4"  
DN80 - DN100 - DN150 Flanged

### Order Information

Please provide the following information in case of order

- Maximum flow rate : m<sup>3</sup>/h
- Maximum network/operating pressure : bar
- Main pipeline diameter : mm
- Valve connection type
- Maximum valve inlet pressure : bar
- Minimum valve inlet pressure : bar
- Desired outlet pressure : bar

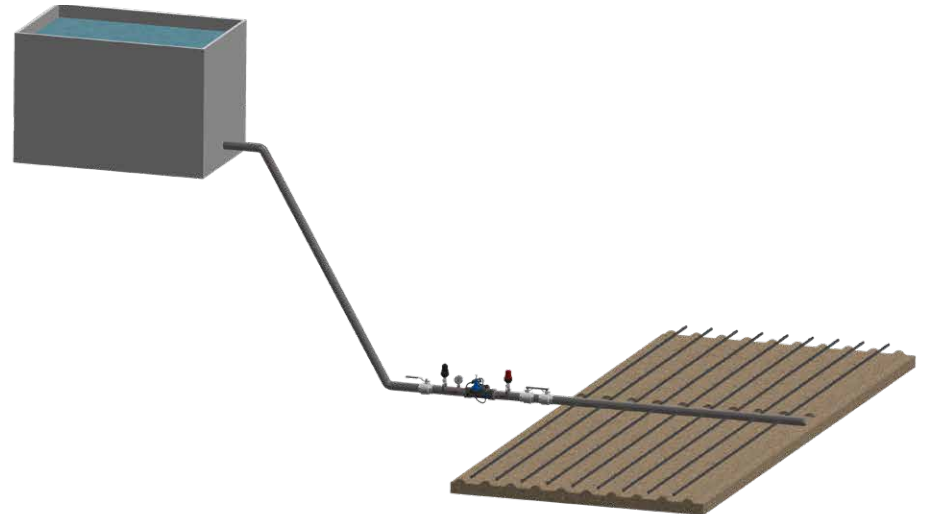

## Assembly

- After connecting the 3 number finger filter to the valve Inlet, the connection to the "II" outlet of the pressure reducing pilot and the "C" outlet of the 3-way valve is provided.
- \* The "I" output of the plastic pilot is connected to the auto "A" output of the 3-way valve with the necessary connection elements.
- \* The connection element is connected to Valve outlet - One output of the Te connection element is connected to the pilot's "III" output and the other is connected to the manometer.
- Valve rated diameter should be the same or a small rated diameter as the line diameter.
- In the direction of the arrow indicated on the valve Mount.
- Isolation valves (butterfly or sliding valve etc.) in the line Assembly of the valve.B) it is recommended to use air discharge valve, quick pressure discharge control valve (QR) and dirt retaining valves.
- \* Cavitation risk during pressure drop is dangerous for valve body. Adjust the output pressure value you want to adjust by looking at the cavitation chart or contact our company.

- 1 Pressure Lowering Pilot
- 2 Three-Way Valve
- 3 Finger Filter
- 4 Manometre
- 5 Pressure Adjustment Bolt

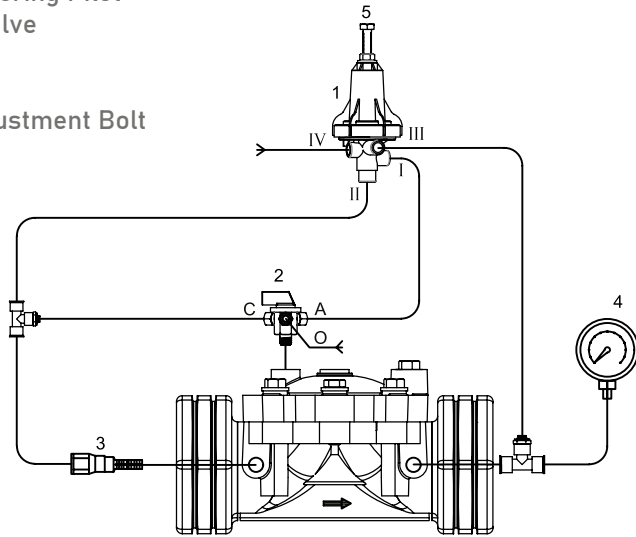

## Adjustment

- Turn on the pump or turn on the mains main valve and give water to the system.
- Keep the spherical valve indicated by "2" in auto position.
- Adjust the adjustment bolt of the pressure reducing pilot valve indicated by "1" by looking at "4" to "5" manometers according to the desired output pressure value. When you turn the adjustment Bolt Clockwise, the output pressure value increases, otherwise it decreases in the direction.
- \* After setting the adjustment point, tighten the control nut under the adjustment Bolt.

## Plastic Hydraulic Control Valves

TYPHOON Plastic Hydraulic Control Valves are designed as automatic control valves operated using diaphragm line pressure, providing reliable and precise flow control in agricultural irrigation, drinking water lines, filtration, and industrial applications. These valves adapt to system pressure and flow changes without requiring manual intervention, contributing to continuous and efficient operation.

The valve's body and diaphragm design ensures smooth flow with minimal pressure loss and increases energy efficiency. Because there are no bearings, bushings, or shafts in the body, the valve has a long lifespan and minimal maintenance requirements. The diaphragm, the sole moving part of the valve, provides precise and reliable control in the system and maintains its performance even during long-term use.

Thanks to their durable construction and automatic operation, TYPHOON Plastic Hydraulic Control Valves are preferred in a wide range of applications, from agricultural irrigation lines to drinking water distribution systems, from filtration units to industrial process lines. Flexible installation options and reliable performance offer long-lasting and efficient solutions suitable for a variety of operating conditions.

Plastic hydraulic control valves are available in flanged, threaded, angled, and Y-type varieties.



## Working Principles

Plastic hydraulic control valves are pressure-controlled valves that use the water pressure in the system to automatically shut off the flow or partially control it. Thanks to their durable plastic body construction, they offer high resistance to corrosion and are safely used especially in agricultural irrigation, landscaping, and industrial water applications.

These valves change the position of the diaphragm using the pressure on the line. The pressure difference between the upper and lower chambers of the diaphragm causes the valve to switch to the open, closed or modulated position. The control signal is usually transmitted via a pilot valve, pressure regulator or solenoid control system.

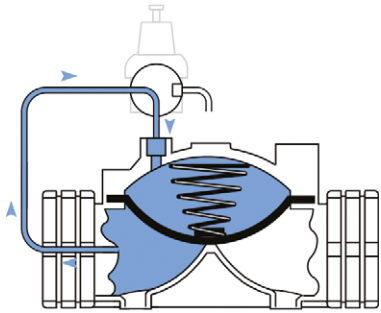

### Valve Closing Mode

In the closed position, line pressure is applied to the upper chamber of the valve diaphragm. The pressurised water filling the upper chamber pushes the diaphragm downwards, ensuring that the main valve seat is fully seated. In this state, the valve completely cuts off the flow and closes the line.

Thanks to its plastic body structure, the valve behaves flexibly against sudden pressure changes, ensuring safer system operation. The closing speed can be adjusted using a pilot valve or needle valve to achieve closure within the desired time.

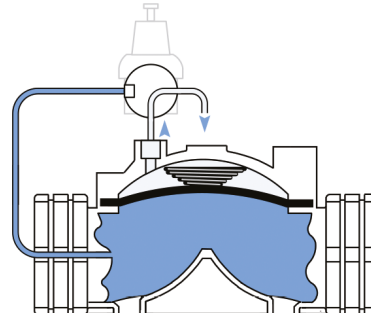

### Valve Opening Mode

In the open mode, the pressure in the upper chamber of the diaphragm is released via the control line or pilot system. When the pressure in the upper chamber drops, the line pressure acts on the lower surface of the diaphragm and the flap moves upwards, opening the valve.

In this case, the fluid flows freely through the valve body. The opening speed can again be adjusted using control valves or regulation elements. The plastic body reduces friction losses, allowing water to flow more efficiently and quietly.

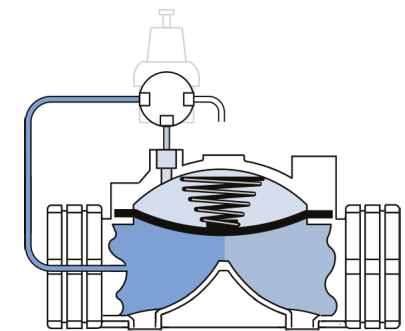

### Modulating Mode

In modulation mode, the valve operates in a partially open position to maintain a constant system pressure or flow rate. This mode is particularly used in pressure reducing, flow control or level control systems. Pilot valves or sensor-supported control systems optimise the valve opening by continuously adjusting the pressure on the diaphragm.

In plastic valves, this mode provides high response sensitivity thanks to both the lightweight construction and the flexible diaphragm design. This reduces pressure fluctuations, increases system stability and maintains energy efficiency.

## Threaded / Regular Body

### Main Components

#	Material Name	Material Type
1	Body	Glass Fiber Reinforced Polyamide
2	Diaphragm	Natural Rubber
3	Spring Wedge	Polypropylene
4	Spring	SST 302
5	Cover	Glass Fiber Reinforced Polyamide
6	Washer	A2 Stainless Steel
7	Bolt	A2 Stainless Steel
8	Nut	Brass

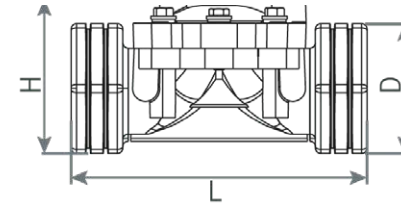

### Dimensions and Weight

	DN		D		L		H		Weight	
	inch	mm	inch	mm	inch	mm	inch	mm	Lbs	Kg
¾	¾	20	1,73	44	5,51	140	2,36	62,50	0,66	0,30
1	1	25	1,73	44	5,51	140	2,36	62,50	0,66	0,30
1½	1½	40	2,48	63	7,91	201	4,28	100,00	2,54	1,15
2	2	50	2,95	75	8,07	211	4,33	105,50	2,65	1,20
2½	2½	65	3,66	93	8,64	219	4,64	112,50	3,09	1,40
3"R	3"R	80R	4,33	110	8,78	223	4,88	124,50	3,42	1,55

### Pressure Loss Table

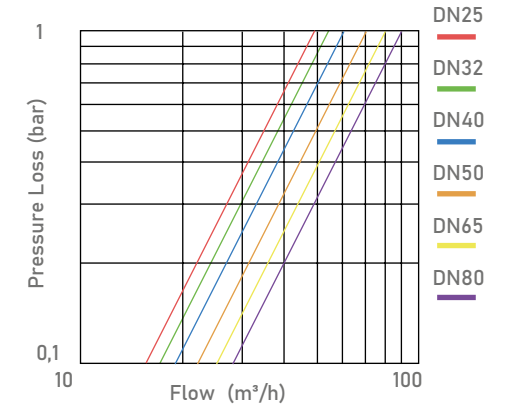

### Hydraulic Performance

	inch	mm	inch	mm	inch	mm	inch	mm	inch	mm	inch	mm
Valve Diameter	¾	25	1	32	1½	40	2	50	2½	65	3"R	80R
Kv m³/h@1bar	50		55		60		70		80		90	
Cv gmp@1psi	56		66		69		81		92		104	

$$Kv(Cv) = Q \cdot \sqrt{G/\Delta P}$$

**Kv** : Valve Flow Coefficient (Flow rate at 1 Bar Pressure Loss m³/h @ 1 Bar)

**Cv** : Valve Flow Coefficient (Flow Rate at 1 Psi Pressure Loss Gpm @ 1 Psi)

**Q** : Flow (m³/h, gpm)

**Cv = 1,155Kv**

**ΔP** : Pressure Loss(bar, psi)

**G** : Specific Gravity of Water (Water=1.0)



### Model

Connection	Threaded	
Material	Glass Reinforced Polyamide	
Body	Globe	
Current Diameters	inch	mm
	¾	25
	1	32
	1½	40
	2	50
	2½	65
	3"R	80R
Maxi. Working Pressure	10 Bar	

## Flanged - Threaded / Large Body

### Main Components

#	Material Name	Material Type
1	Body	Glass Fiber Reinforced Polyamide
2	Flange Adapter	Glass Fiber Reinforced Polyamide
3	Flange	Glass Fiber Reinforced Polyamide
4	Diaphragm	Natural Rubber
5	Spring Mount	Polypropylene
6	Spring	SST302
7	Cover	Glass Fiber Reinforced Polyamide
8	Bolt	8.8 Coated Steel
9	Nut	8.8 Coated Steel
10	Washer	8.8 Coated Steel



### Dimensions and Weight

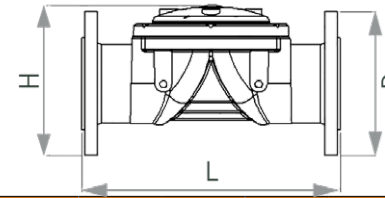

DN		D		L		H		Weight	
inch	mm	inch	mm	inch	mm	inch	mm	Lbs	Kg
3	80	7,87	200	14,57	370	8,66	220	14,52	6,60
4	100	9,00	227	14,57	370	9,17	233	16,28	7,40
5	125	10,11	257	13,35	390	9,96	253	16,53	7,5
6	150	11,02	280	15,55	395	10,43	265	16,76	7,6

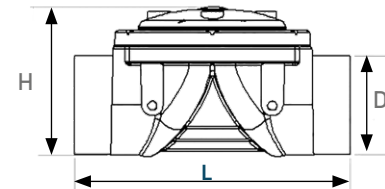

DN		D		L		H		Weight	
inch	mm	inch	mm	inch	mm	inch	mm	Lbs	Kg
3	80	4,72	120	11,58	294	7,05	179	10,25	4,65
4	100	4,72	120	13,23	336	7,28	185	9,70	4,40

### Hydraulic Performance

	inch	mm	inch	mm	inch	mm	inch	mm
Valve Diameter	3	80	4	100	5	125	6	150
Kv m³/h@1bar	166		208		215		220	
Cv gmp@1psi	193		242		248		260	

$$Kv(Cv) = Q \cdot \sqrt{G/\Delta P}$$

Kv : Valve Flow Coefficient (Flow rate at 1 Bar Pressure Loss m³/h @ 1 Bar)  
 Cv : Valve Flow Coefficient (Flow Rate at 1 Psi Pressure Loss Gpm @ 1 Psi)  
 Q : Flow (m³/h, gpm)

Cv = 1,155Kv  
 ΔP : Pressure Loss(bar, psi)  
 G : Specific Gravity of Water (Water=1.0)

### Pressure Loss Table

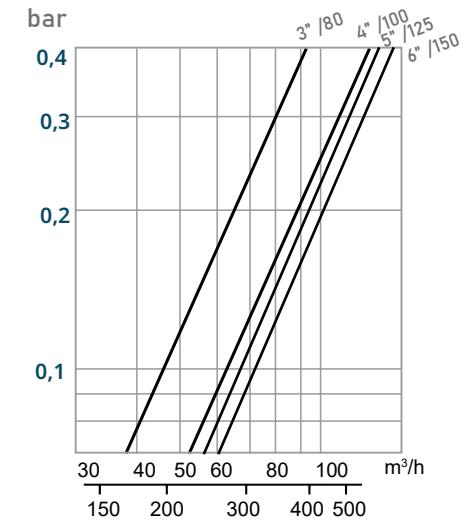

### Model

Connection	Flanged / Threaded	
Material	Glass Reinforced Polyamide	
Body	Globe	
Current Diameters	inch	mm
	3	80
	4	100
	5	125
Maxi. Working Pressure	6	150 (Flanged)
	10 Bar	

## Threaded / Angled Body

### Main Components

#	Material Name	Material Type
1	Body	Glass Fiber Reinforced Polyamide
2	Diaphragm	Natural Rubber
3	Spring Mount	Polypropylene
4	Spring	SST 302
5	Cover	Glass Fiber Reinforced Polyamide
6	Bolt	A2 Stainless Steel
7	Washer	A2 Stainless Steel
8	Nut	Brass

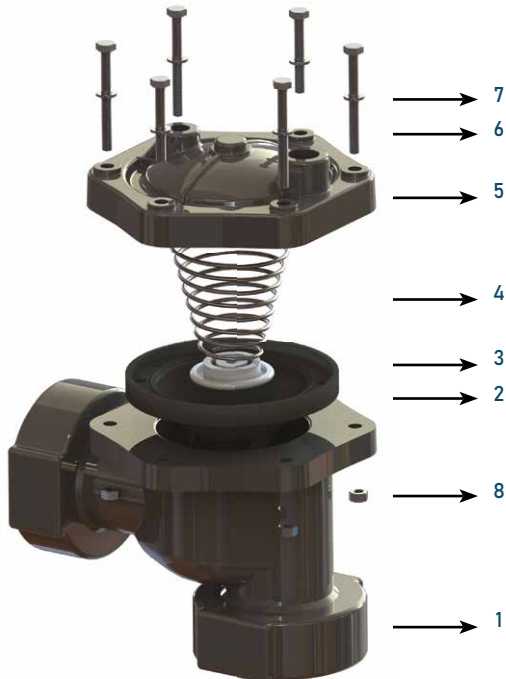

### Dimensions and Weight

DN		D		L		H		Weight	
inch	mm	inch	mm	inch	mm	inch	mm	Lbs	Kg
2	50	3,4	86	8	203	6,77	172	2,86	1,30
2½	65	3,4	86	8	203	6,77	172	2,86	1,20
3"R	80R	3,4	86	8	203	6,77	172	2,86	1,06

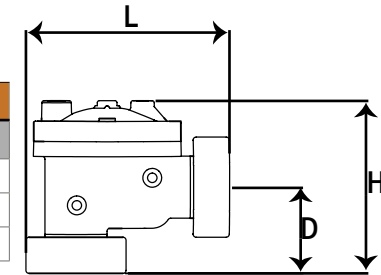

### Pressure Loss Table

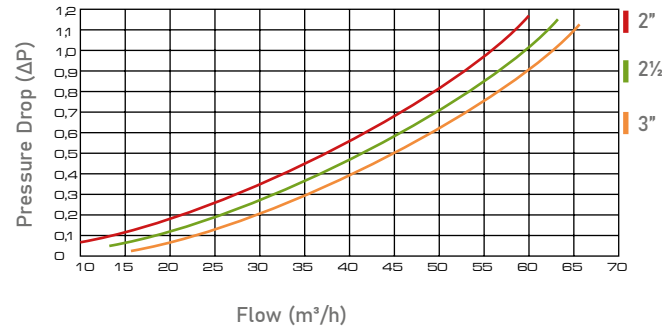

	inch	mm	inch	mm	inch	mm
Valve Diameter	2	50	2½	65	3"R	80R
Kv m³/h@1bar	51,0		56,0		66,0	
Cv gmp@1psi	58,9		64,7		76,2	

### Model

Connection	Threaded	
Material	Glass Reinforced Polyamide	
Body	Globe	
Current Diameters	inch	mm
	2	50
	2½	65
	3"R	80R
Maxi. Working Pressure	10 Bar	

$$Kv(Cv) = Q \cdot \sqrt{G/\Delta P}$$

**Kv** : Valve Flow Coefficient (Flow rate at 1 Bar Pressure Loss m³/h @ 1 Bar)  
**Cv** : Valve Flow Coefficient (Flow Rate at 1 Psi Pressure Loss Gpm @ 1 Psi)  
**Q** : Flow (m³/h, gpm)

**Cv** = 1,155Kv  
**ΔP** : Pressure Loss(bar, psi)  
**G** : Specific Gravity of Water (Water=1.0)

# Technical Specifications

# Plastic Hydraulic Control Valves

## Flanged - Threaded / Angled Large Body

### Main Components

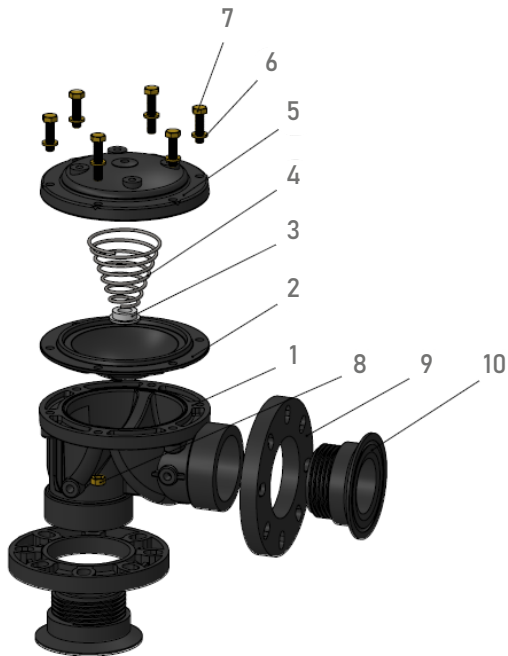

### Dimensions and Weight

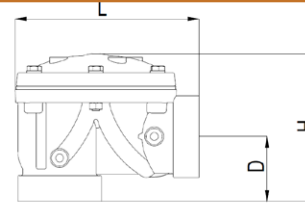

DN		D		L		H		Weight	
inch	mm	inch	mm	inch	mm	inch	mm	Lbs	Kg
3	80	3,9	99	10,9	277	8,78	223	11,13	5,05
4	100	3,9	99	10,9	277	8,78	223	10,8	4,90

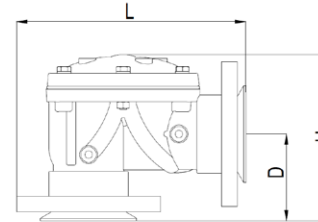

DN		D		L		H		Weight	
inch	mm	inch	mm	inch	mm	inch	mm	Lbs	Kg
3	80	5,08	129	13,42	341	9,96	253	15,43	7
4	100	5,35	136	14,84	377	10,28	261	17,19	7,8
6	150	6,38	162	16,18	411	11,14	283	17,64	8

### Model

Connection	Flanged / Threaded	
Material	Glass Reinforced Polyamide	
Body	Globe	
Current Diameters	inch	mm
	3	80
	4	100
Maximum Working Pressure	10 Bar	

$$Kv(Cv) = Q \cdot \sqrt{G/\Delta P}$$

**Kv** : Valve Flow Coefficient (Flow rate at 1 Bar Pressure Loss m<sup>3</sup>/h @ 1 Bar)  
**Cv** : Valve Flow Coefficient (Flow Rate at 1 Psi Pressure Loss Gpm @ 1 Psi)  
**Q** : Flow (m<sup>3</sup>/h, gpm)

**Cv** = 1,155Kv  
**ΔP** : Pressure Loss(bar, psi)  
**G** : Specific Gravity of Water (Water=1.0)

## Manual Flow Controlled

The flow rate in the line can be reduced using the flow control lever on the cover.

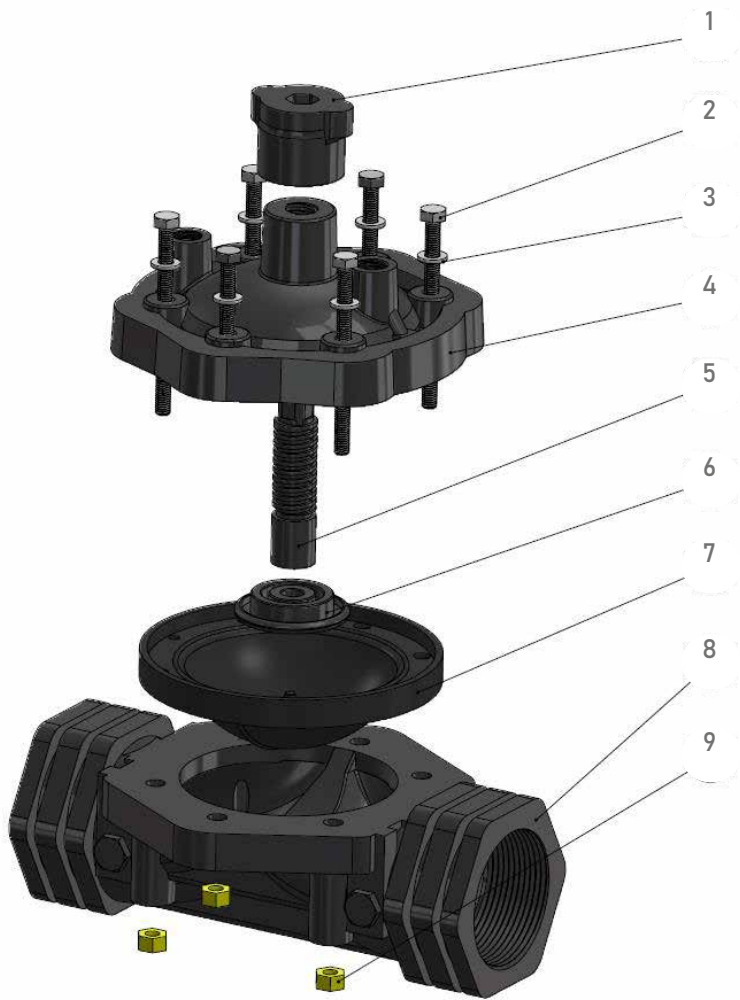

#	Material Name	Material Type
1	Flow Cover	Polypropylene
2	Bolt	Stainless Steel
3	Washer	Stainless Steel
4	Cover	GRP
5	Flow Shaft	Polypropylene
6	Spring Stamp	Polypropylene
7	Diaphragm	Natural Rubber
8	Body	GRP
9	Nut	Brass

Current Diameters	
Threaded	3/4"
	1"
	1 1/2"
	2"
	2 1/2"
	3"
Flanged	3"L
	4"L
Angled Threaded	DN80
	DN100
	2"
Angled Flanged	2 1/2"
	3"
Angled Flanged	DN80
	DN100

Two-Way Solenoid Usage

It is controlled by a two-way solenoid valve connected to the main valve. Normally closed, the valve switches to the open position when a signal is received or when manually operated.

Valve Opening Mode

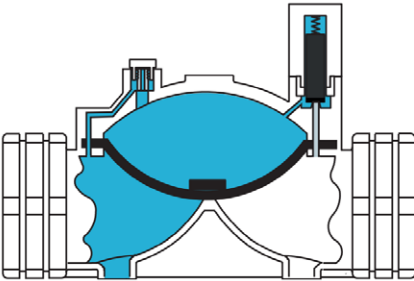

Valve Closing Mode

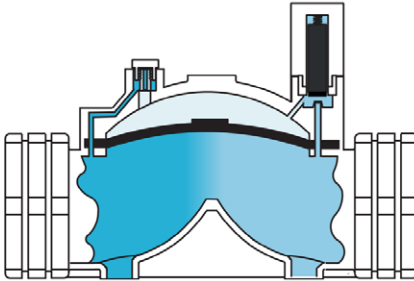

Pressure Loss Table

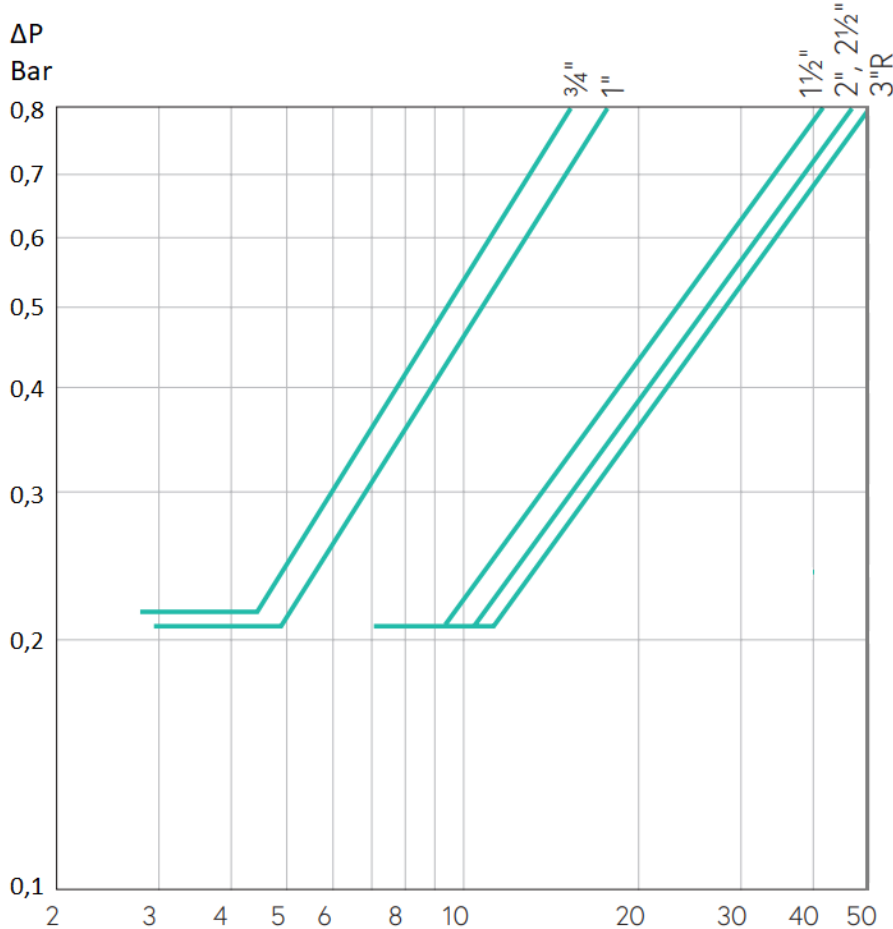

### Y Type Plastic Hydraulic Control Valve



TYPHOON Plastic Y-Type Automatic Hydraulic Control Valves are manufactured from plastic in a „Y“ body design, ensuring minimal pressure loss, cavitation, and noise, even under challenging operating conditions with high pressure differentials thanks to their high modulation capacity. This special body structure allows the valve to direct flow most efficiently, optimizing system performance and ensuring long-lasting operation.

The valve is equipped with a dual-chamber diaphragm actuator and operates as standard with two control chambers. It can be used as a single-chamber system without adding an additional control chamber when needed. A V-Port disc option is also available for precise control in low-flow applications. Thanks to the valve shaft rigidly mounted on the valve body, the valve operates smoothly and with control, opening and closing completely leak-tight without causing any pulsation.

TYPHOON Plastic Y-Type Automatic Hydraulic Control Valves can be customized to perform different functions by adding various control components to the Basic plastic valve body. These valves provide reliable and precise flow control in a variety of applications, including agricultural irrigation, drinking water pumping lines, fire systems, filtration, and industrial applications. With their durable plastic bodies and flexible application options, TYPHOON Y-Type valves ensure efficient and long-lasting system operation.

#### **Order Information**

Please provide the following information in case of order

- Maksimum Flow miktarı : m<sup>3</sup>/h
- Maksimum şebeke / işletme basıncı : bar
- Ana boru hat çapı : mm
- Vana bağlantı tipi

#### **Features**

- Its simple structure makes it easy to use and maintain.
- Low cost.
- Operates over a wide pressure range.
- Flawless modulation even at low flow rates.
- Flexible diaphragm for smooth on-off operation.
- Reinforced diaphragm and internal spring for complete sealing.
- Epoxy-Polyester coating for long life.
- A wide range of control applications are available with the use of various pilot valves.
- Ability to operate in horizontal and vertical positions in application areas.

# Technical Specifications

## Y Type Plastic Hydraulic Control Valves

### Main Components

#	Material Name	Material Type
1	Body	Glass Fiber Reinforced Polyamide
2	Valve	Stainless Steel
3	Sealing Rubber	EPDM
4	Cup	Stainless Steel
5	Shaft	Stainless Steel
6	Bottom Cover	Glass Fiber Reinforced Polyamide
7	Diaphragm	Natural Rubber
8	Diaphragm Support	Stainless Steel
9	Spring	Stainless Steel
10	Top Cover	Glass Fiber Reinforced Polyamide
11	Nut	Stainless Steel
12	Nut	Brass
13	Bolt	Stainless Steel
14	Bolt	Stainless Steel
15	Washer	Stainless Steel

Operating Temperature: Maximum 80°C  
 Operating Pressure: Maximum 10 Bar

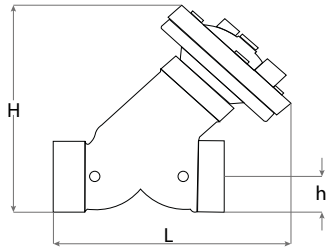

### Dimensions and Weights

DN		L		h		H		Weight	
inch	mm	inch	mm	inch	mm	inch	mm	Lbs	Kg
2	50	6,49	165	1,49	38	8,86	225	3,86	1,75
¾	20	5,31	135	1,02	26	5,23	133	2,09	0,95
1	25	5,31	135	1,02	26	5,23	133	2,20	1,00
1¼	32	5,31	135	1,14	29	5,23	133	2,31	1,05
1½	40	8,78	165	1,49	38	8,86	225	3,86	1,75
2	50	6,49	165	1,49	38	8,86	255	3,86	1,75

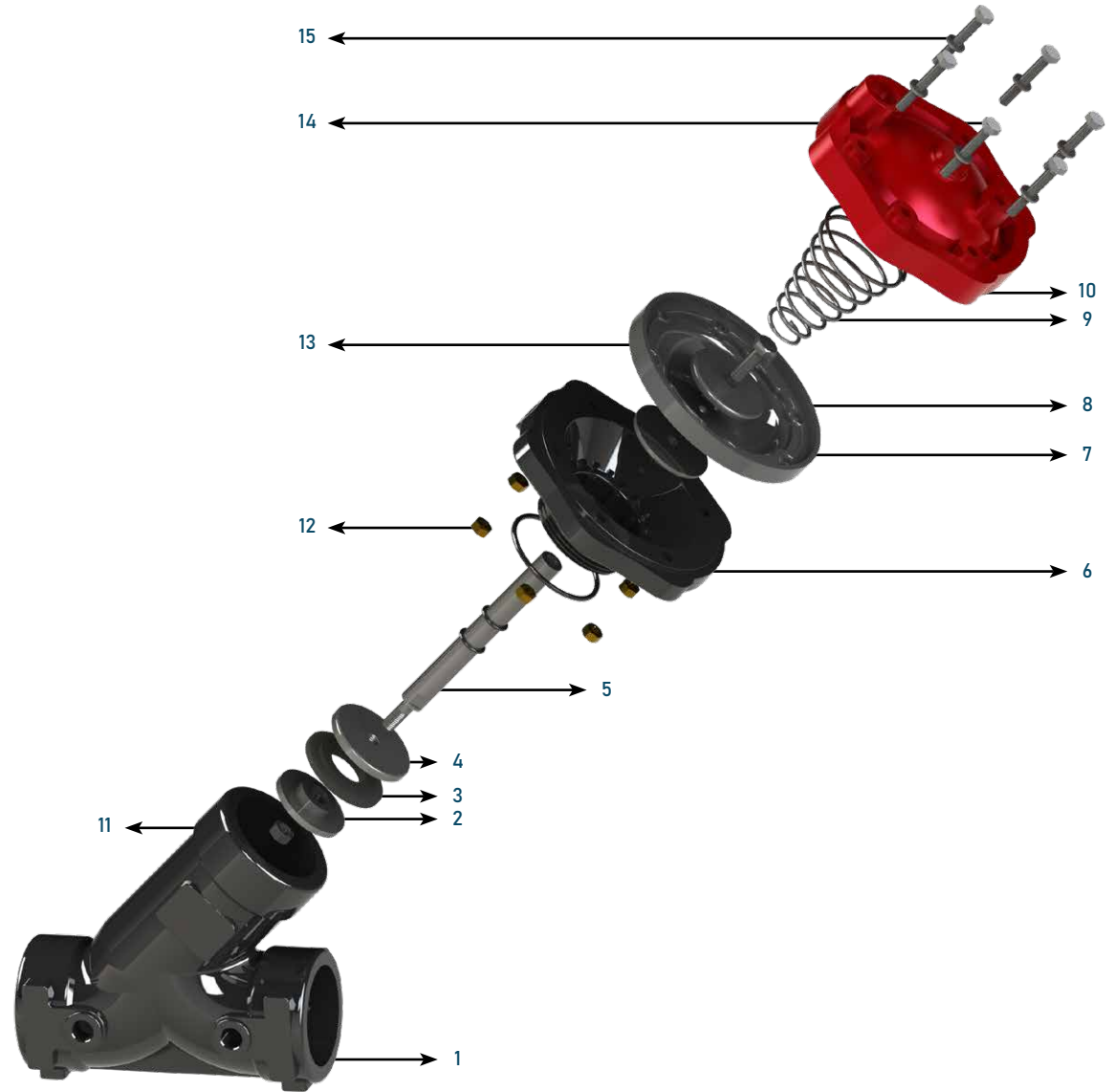

Pressure Loss Table

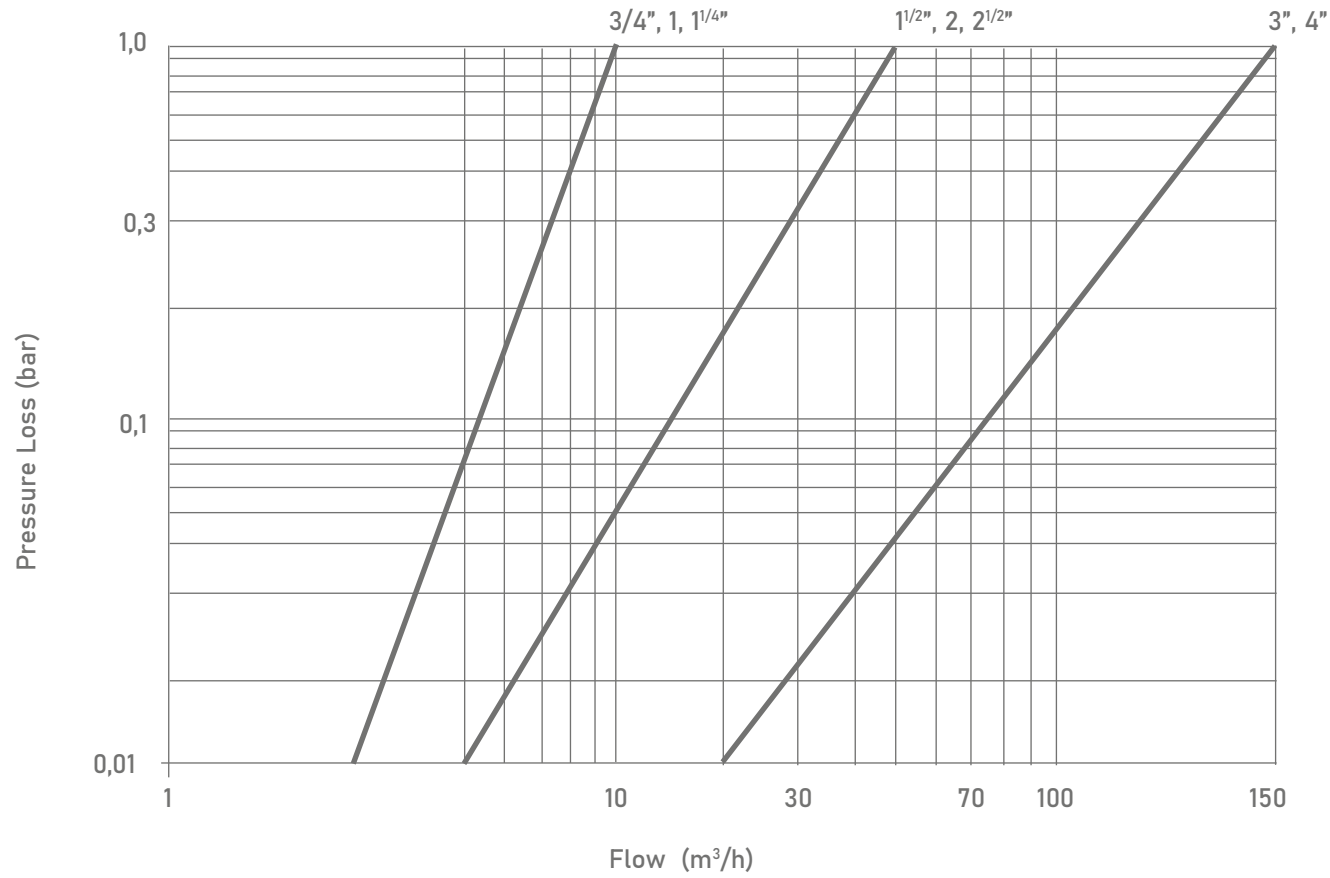

## Working Principles

These are automatic control valves with double-chamber diaphragm actuators and flap closure, used to perform the desired hydraulic operations using line pressure without the need for energy sources in the network line.

P1: Inlet Pressure  
 P2: Outlet Pressure  
 P3: Actuator Pressure

Pyay: Spring Force  
 A: Valve Effect Area

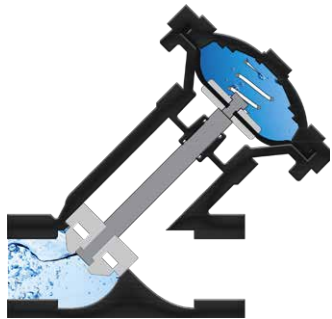
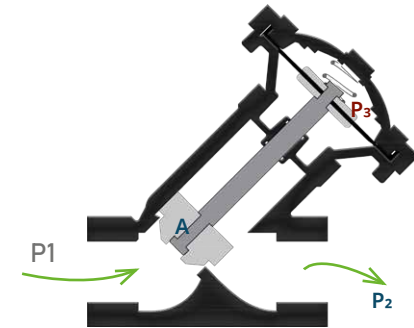

**Valve Closing Mode**

When the pilots on the main control valve deliver the inlet pressure (P1) to the diaphragm, the water creates hydraulic force. This force causes the valve disc to seat against the body seat, ensuring the valve closes completely without leakage.

If we examine the forces involved in closing the valve,  $P3 \times 3A + Pyay > P1 \times A$

is obtained. When there is no external effect on the area indicated by the P3 pressure, the P3 pressure equals the maximum P1 pressure. The  $P3 \times 3A$  force overcomes the  $P1 \times A$  force together with the spring force, and the valve closes completely without leakage.



**Valve Opening Mode**

The inlet pressure of the main control valve overcomes the Pyay force, which assists in the closing operation, and the force created by the P3 pressure on the diaphragm, thereby opening the valve.

If we examine the forces involved in opening the valve:

$$P1 \times A > Pyay + P3 \times 3A$$

is obtained. Since the area represented by the P3 pressure is discharged, the differential pressure becomes 0. Thus, the  $P1 \times A$  force overcomes the spring force, enabling the valve to open. The spring force determines the minimum opening pressure required to open the valve.

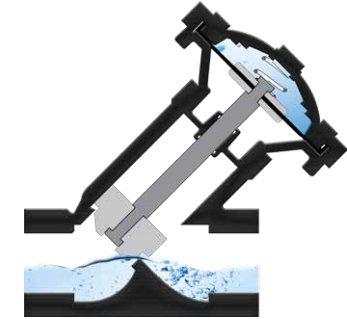

**Modulating Mode**

Ana kontrol vanasının üzerinde bulunan pilotlar alt ensures operation in modulation mode by continuously monitoring the pressure of the winterising valve.

If the forces involved in the valve's operation in modulation mode are examined:

$$P1 \times A + P2 \times 3A = P3 \times 3A + Pyay + P2 \times A$$

is obtained. The pilot valve, which enables the valve to operate in modulation mode, regulates the P2 and P3 pressures to achieve force equilibrium. Thus, the valve operates in modulation mode.

### Main Components

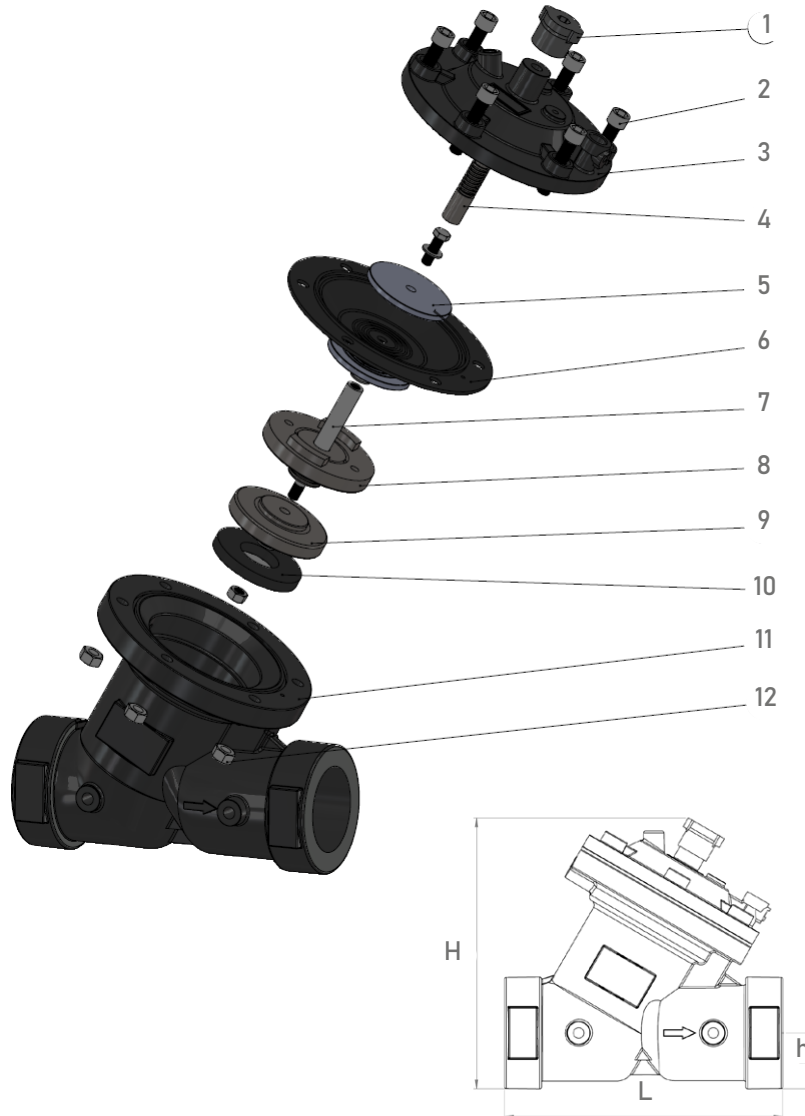

Connection	DN		L		h		H	
	inch	mm	inch	mm	inch	mm	inch	mm
Threaded	3/4"	20	6,50	165	1,02	26,0	6,30	160
	1"	25	6,50	165	1,02	26,0	6,30	160
	1 1/4"	32	6,50	165	1,18	30,0	6,46	164
	1 1/2"	40	8,78	223	1,46	37,0	8,94	227
	2"	50	8,78	223	1,57	40,0	9,06	230
	2 1/2"	65	8,98	228	1,89	48,0	9,37	238
	3"	80	11,81	300	2,40	61,0	11,61	295
Flanged	2"	50	11,28	261	3,25	82,5	10,63	270
	2 1/2"	65	11,28	267	3,64	92,5	11,02	280
	3"	80	15,59	396	3,84	97,5	12,99	330
	4"	100	15,59	396	4,47	113,5	13,62	346
Victaulic	3"	80	11,81	300	2,05	52,0	11,22	285
	4"	100	11,81	300	2,26	57,5	11,42	290





# Trade Fairs





Kemalpaşa OSB Mahallesi Kuzey Sanayi Caddesi  
Dış Kapı No:13  
Kemalpaşa / İzmir

+90 232 458 49 99  
+90 232 458 57 67

TYPHOON

[www.tayfursu.com.tr](http://www.tayfursu.com.tr) | [info@tayfursu.com.tr](mailto:info@tayfursu.com.tr)

Her  
Fabrika  
Bir  
Kaledir\*

*H. Atatürk*



\* Every factory is a fortress